

LinkGem™ Canister

**Wireless side-opening canister for
eSignature applications**



Model T-RFS261-C1B/2B/3B

Features

Secure 2.4 GHz FHSS wireless communication system

77 separate channels allow multi-system operation

Reliable, rugged signing surface

4.6" x 1.0" active area

PenGem™ active electromagnetic pen

over 30 million tip activation cycles

Patent-pending Drive-Off Alert

Alarm sounds on canister and receiver when canister is out of range

Built-in pen storage, space to enclose paper forms or receipts

provide users with paper records of their transactions

E-Sign law-compliant biometric signatures and software

encryption, compression, and authentication for eCommerce



Applications

Drive-through receipt automation for banks, credit unions, or pharmacies

Description

The Topaz Model T-RFS261-C1B/2B/3B canister, along with the Topaz Model L-RFB-100-B base unit, is a complete and versatile signature capture system for use with remote drive-through environments. Topaz canisters can eliminate paper forms by binding electronic signatures to documents or transactions. Information is transferred through a frequency-hopping spread-spectrum 2.4 GHz wireless link, ensuring that data is securely and reliably transmitted between the user and host. The convenient design of the canister features internal pen and document storage, drive-off alert, automatic activation upon opening, and a power saving standby mode. The base unit can be hot-plugged into the computer and need not be connected during the boot process. The active electromagnetic pen is designed for a long life of over 30 million tip activation cycles, and the plastic tip is easily replaceable with no dis-assembly required. Software support is available at no extra charge and includes ActiveX, Java, Wintab drivers, and a shared C library for the capture, encryption, formatting, and secure processing of signatures including bmp, tif, jpg, emf, and wmf image formats. Topaz SigPlus software is compliant with eSign, state and federal digital signature regulations by virtue of its ability to bind and encrypt the signature to a document or electronic form data. Examples and software plug-ins are bundled with the tablet. Base adapters are available with standard RS-232 (serial) or USB interfaces.

Topaz Systems, Inc.
650 Cochran Street Suite 6 Simi Valley, CA 93065
phone: 805 520 8282 fax: 805 520 0867
www.topazsystems.com

Specifications

PARAMETER	SPECS	REMARKS
Transmit distance	500 ft. min (Line-of-sight) 50 ft. min (non line-of-sight)	Environment dependent
Battery life	70 hours max (standby) 390 minutes max (capture mode)	
Signature resolution	410 points/inch	
Pen life	3 million tip activation cycles	
Software	ActiveX control, Java bean, biometric verification, encryption, database-compatible ASCII, Wintab	Compatible with Win98, Me, NT, 2000, XP; MS Word, Excel; Lotus Notes, Domino; Adobe Acrobat; VB, VC++, Delphi, ASP, EMF
Power	+7.2 Vdc, 175 mA max	2 Eveready ER-P730 NiMH battery packs (included)
MTBF	more than 100,000 hours	
Maximum ratings	operating: 0 to 50 deg C storage temp: -20 to 65 deg C humidity %: 10 to 90	non-condensing

Ordering Information

Model T-RFS261-C1B *4" dia. side-opening signature-capture canister*

Based on SOTA10

Standard Bumpers

Fits: LeFebure, Tel-Air 10 systems

Model T-RFS261-C2B *4" dia. side-opening signature-capture canister*

Based on SO4L

Bull-nosed bumpers

*Fits: Diebold VAT2, all LeFebure systems, all Tel-Air systems
except 10 and 45*

Model T-RFS261-C3B *4.5" dia. side-opening signature-capture canister*

Based on SO45

Fully-tapered bumpers

*Fits: most Hamilton, ComCo, Diebold Vat 4 & 6, and Mosler
Trans- Vista 4000 systems*

L-RFB-100-B *matching RF base unit (required)*

For more information or to place an order, contact the Topaz Systems sales dept. at (805) 520 8282

Topaz Systems, Inc.
650 Cochran Street Suite 6 Simi Valley, CA 93065
phone: 805 520 8282 fax: 805 520 0867

www.topazsystems.com

Mechanical Outline

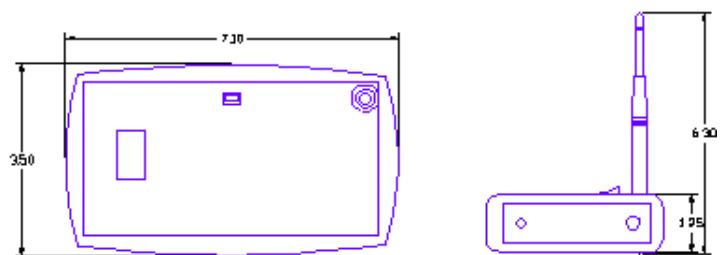
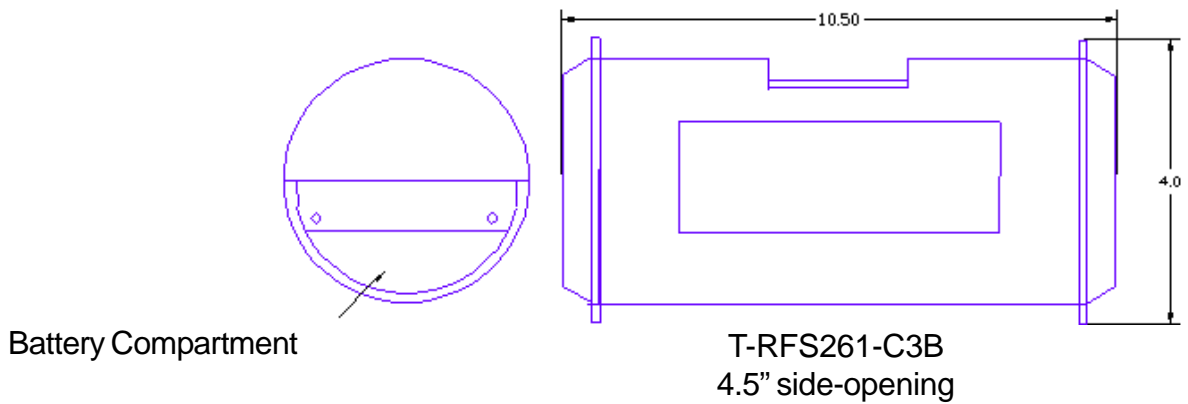
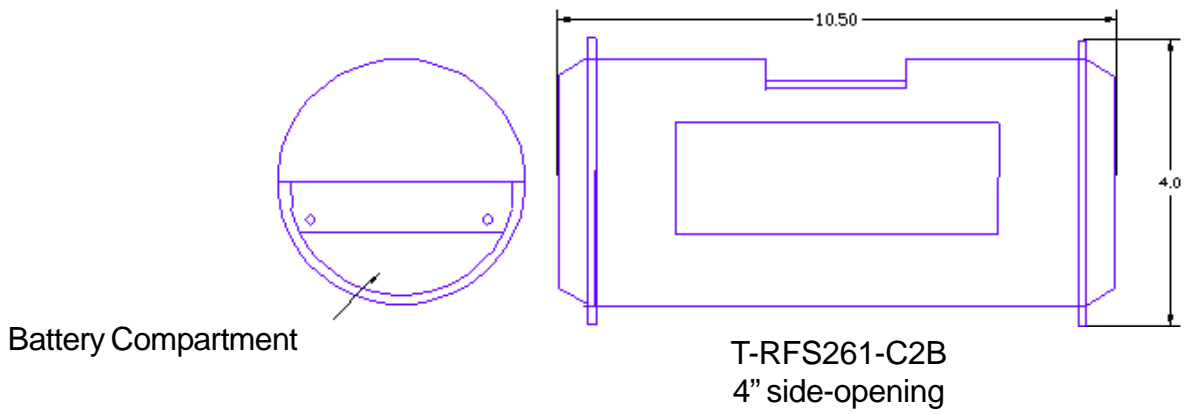
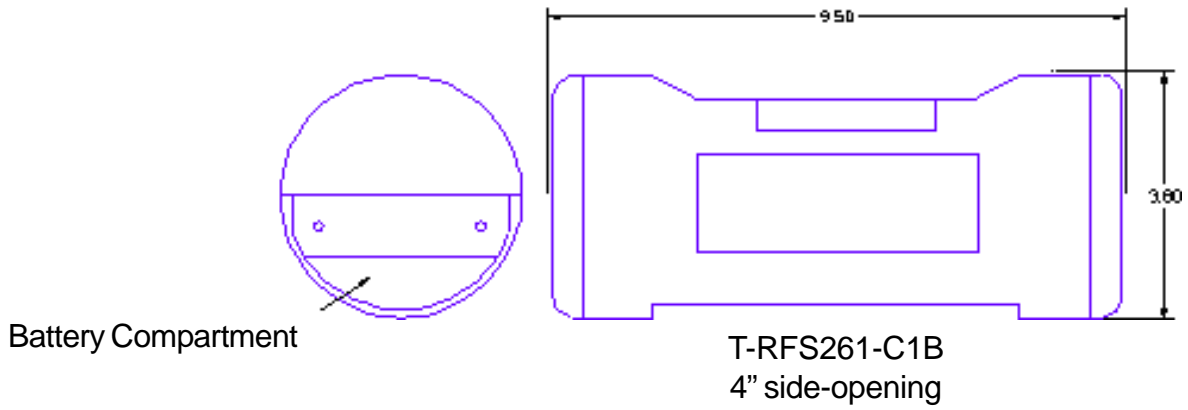

L-RFB-100-B Base Unit

Product Photos



T-RFS261-C2B/-C3B
Side-opening canister

T-RFS261-C1B
Side-Opening Canister



L-RFB-100-B
Base unit

Topaz tablets and pens are designed and manufactured to the highest standards of quality and for ease of use. Every tablet and pen comes with the Topaz standard 1-year warranty and commitment to your complete satisfaction. Highly-rugged construction and responsive field support keep you up-and-running. Extended warranty is available.

Topaz Systems, Inc.
650 Cochran Street Suite 6 Simi Valley, CA 93065
phone: 805 520 8282 fax: 805 520 0867

www.topazsystems.com